



Workplace

SLIP RESISTANT MATTING



www.plastexmatting.com



Plastic Extruders Ltd.

plastex

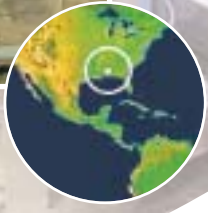

Our Mission *A Mat for All Reasons*

Our mission is to add to our distributors, and in turn their customers, profitability, safety, productivity and style by designing and manufacturing cutting edge matting for all work, education and leisure environments.

Our Values

Plastic Extruders Ltd (Plastex) are a second generation family run firm with long serving employees who take personal responsibility for maintaining the highest service standards and delivering the right solution on time and on budget.

Working with you to meet your needs

Through our design and innovation programme we work with our customers to constantly improve the form, function and cost effectiveness of our products.

So, though we have an extensive range suitable for most applications, we often fulfill individual customer needs by producing bespoke solutions. If you feel you may have one we would be pleased to hear from you.



PETER O'SULLIVAN Sales Director DAVID O'SULLIVAN Managing Director

Plastic Extruders Ltd UK & Plastex Matting Inc USA





Plastex and the environment

As a global supplier with manufacturing plants in the UK and the USA, we constantly seek to reduce the environmental impact of our manufacturing processes. For example all our black matting is made with up to 100% post-industrial recycled material, but always with a minimum content of 30%.

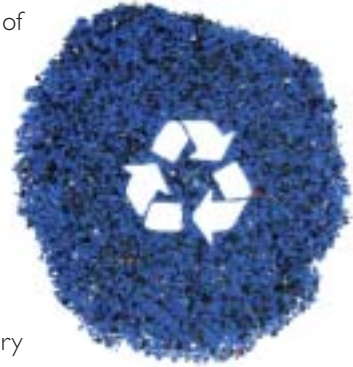

To further minimise impact and avoid waste, we don't throw away any materials. All our factory trimmings and production process scrap are re-used in our own production. We do not re-sell any material to 3rd party reproprocessors.

R.E.A.C.H - Registration, Evaluation, Authorisation and Restriction of Chemical Substances

The European Community R.E.A.C.H regulation (2007) gives manufacturers the responsibility of providing high level human and environmental protection from the use of chemicals in manufacturing.

Plastex does not use any substances currently included on the SVHC (Substances of Very High Concern) list under R.E.A.C.H, including "DEHP" Di(2-ethylhexyl) phthalate, also known as Di-octyl phthalate (DOP), plasticiser.

Further information can be found at www.plastexmatting.com.

Matting & flooring
manufactured in Europe
and the USA.

- distributed worldwide



Which Plastex product is right for you?

The chart below will help you choose the right mat for the right reasons, but if you have any questions contact us - we'll be delighted to help.

| PRODUCT | SLIP RESISTANCE | DRAINAGE/ SPILLAGE | WEAR | SITUATION | USAGE | FLOOR |
|-----------------------------------|-----------------|--------------------|------|-----------|---|------------------------|
| GENERAL PURPOSE | | | | | | |
| Vynagrip p4-5 | | | | | Hard wearing, heavy usage, long term | Specific area solution |
| Heronair p6-7 | | | | | Cushions against breakages, good general purpose | Specific area solution |
| Floorline p8 | | | | | Ideal for light usage and cushioning against breakage | Specific area solution |
| Rubbagrid p9 | | | | | For coverage of large areas in the workplace | Large area tile cover |
| WORKSHOP / TOOL ROOM | | | | | | |
| Flexigrid p10 | | | | | Larger components, debris, swarf and heavy spillage | Specific area solution |
| Firmagrip p11 | | | | | Close spaced grid, smaller components and wheeled traffic | Specific area solution |
| FOOD PROCESSING / KITCHENS | | | | | | |
| Herongripa p12 | | | | | Large format grid for intensive food processing | Specific area solution |
| Grip Rock p13 | | | | | Commercial kitchen and food processing | Specific area solution |

Why Slip Resistance?

- Slipping is the most common cause of workplace injury.
- In the USA, slipping deaths are second only to deaths by car accident.
- Each year around 700,000 hospital beds are filled by slip casualties in the UK.
- Litigation, loss of work hours, overtime, temporary cover = increased cost.



Inside or out, clean or not
A mat for all reasons

VYNAGRIP

The ultimate slip resistant matting solution

Built from top quality materials to exacting specification, we believe Vynagrip to be the best heavy duty matting available. Vynagrip carries a very high slip resistant rating (DIN 51130 - R11) as a result of its tread pattern.

Excellent slip resistance is coupled with a top liquid drainage rating, which also meets the highest international standards, and open grid design to effectively remove liquid and debris.

An independent one year programme of scientific tests by the University of Hertfordshire has proven Vynagrip's anti-fatigue properties, which in turn help boost productivity.

In addition, Vynagrip is hygienic, easy to clean, and provides excellent cushioning, thermal and noise reducing properties.

Standard colours

VYNAGRIP



RED



BLUE

VYNAGRIP PLUS



BLACK

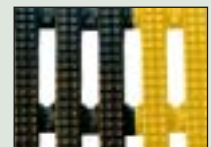

WITH YELLOW BANDS

Other Vynagrip colours available on request.

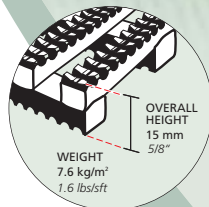

| PRODUCT | HEIGHT mm (in) | LENGTH m (ft) | WIDTH OPTIONS cm (ft) | | |
|------------------|----------------|--------------------------|-----------------------|--------|---------|
| Vynagrip | 15 (5/8") | 5 (16'6") | 60 (2) | 91 (3) | 122 (4) |
| Vynagrip | 15 (5/8") | 10 (33') | 60 (2) | 91 (3) | 122 (4) |
| Vynagrip Black | 15 (5/8") | 5 (16'6") | 60 (2) | 91 (3) | 122 (4) |
| Vynagrip Black | 15 (5/8") | 10 (33') | 60 (2) | 91 (3) | 122 (4) |
| Vynagrip Plus | 15 (5/8") | 10 (33') | 60 (2) | 91 (3) | 122 (4) |
| Vynagrip modules | 15 (5/8") | 120 x 80 (3'11" x 31.5") | 150 x 100 (5' x 3'3") | | |

supplied with factory fitted edging on 3 sides

Product Codes: Vynagrip VYN
Vynagrip Plus VYP



For ancillary range
see page 14





Vynagrip is made from 2 layers of non-porous, flexible PVC that are welded together to create extra strong joints. It is available in rolls or modules with accessories to suit all needs.

VYNAGRIP BLACK

Environmentally friendly Vynagrip black is made from up to 100% recycled material - with a minimum guaranteed content of 30%, giving a 10% lower purchase price.

VYNAGRIP PLUS

Vynagrip with the additional benefit of yellow bands to mark routes and delineate areas.

◆ Very high rated slip resistant certification

◆ Proven anti-fatigue properties

◆ Exceptionally hard wearing

◆ Chemical, oil and acid resistant

◆ Excellent drainage certification

THE MAIN BENEFITS

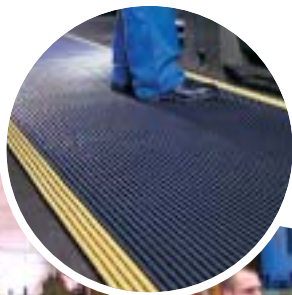

HERONAIR

A hardwearing and versatile work horse

Heronair's open grid construction and 9mm surface height copes effectively with water and spillage dissipation.

Its tubular two layer structure also provides excellent comfort and insulation where cold, hard floors are otherwise an issue, especially where workers are standing for lengthy periods.

Heronair's hollow construction uses less material, so it is an economical alternative too.

Heronair Black is made from recycled factory waste that is in turn an environmentally friendly recyclable product. A minimum 30% recycled content is guaranteed but is often 100%.

Standard colour
BLACK



| PRODUCT | HEIGHT mm (in) | LENGTH m (ft) | WIDTH OPTIONS cm (ft) | | |
|----------------|----------------|---------------|-----------------------|----|-----|
| Heronair - UK | 10 | 10 | 50 | 75 | 100 |
| Heronair - USA | 3/8" | 40' | 2' | 3' | 4' |

Product Code HAR



For ancillary range
see page 14



Slip Resistance Test Results

DIN 51130 R10,V10
ASTM 1677 (0.6/0.6)

◆ Fits any floor

◆ Two layered tubular construction

◆ Minimum 30% recycled content

◆ Excellent cushioning & insulation

◆ Cost effective

THE MAIN BENEFITS



FLOORLINE

Light, economical and comfortable

Light, soft underfoot and decorative. Floorline is simple to roll for cleaning purposes and ideal for bar and catering areas where occasional spillage may occur.

Thanks to a slip resistant surface (DIN 51130 - R11) and open grid design for effective liquid drainage, it's a great performer.

This economical matting insulates against cold, hard floors, even reducing standing fatigue. Ease of handling also ensures light work of installation and suitability for seasonal premises.

Standard colours



RED



BLUE

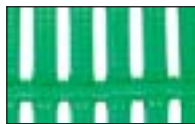

GREEN



BEIGE



WHITE

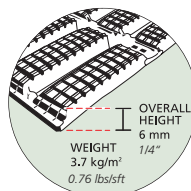

◆ Hollow cushioned surface for comfort

◆ Helps reduce breakages

◆ Ideal for normal footwear

◆ Light & loose lay - easy to clean

◆ Good slip resistance
DIN 51130-R11

THE MAIN BENEFITS

| PRODUCT | HEIGHT mm (in) | LENGTH m (ft) | WIDTH OPTIONS cm (ft) | |
|-----------|----------------|---------------|-----------------------|---------|
| Floorline | 6 (1/4") | 10 (33') | 60 (2') | 91 (3') |

Product Code FLN

Floorline is also suitable for leisure applications, see Barefoot Wetside Safety Matting section.



RUBBAGRID - OPEN

Heavy duty wet area modular mat

With its large format tile and secure interlocking edges Rubbagrid is perfect for irregular shaped areas where drainage is important. The terracotta version is made from animal fat resistant Nitrile rubber making it ideal for food processing.

Standard colours

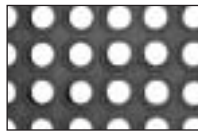

BLACK



TERRACOTTA

| PRODUCT | HEIGHT mm (in) | SIZE cm (ft) |
|----------------|---------------------------------|-------------------------|
| Rubbagrid Open | 15 (5/8") | 91 x 91 (3' x 3') tiles |
| Product Code | RGO - Black RGN - Terracotta | |

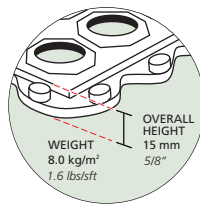

THE MAIN BENEFITS

- ◆ Anti-fatigue properties
- ◆ Modular system withstands wet, greasy environments
- ◆ Nib backing for better drainage and aeration
- ◆ Ramps available



For ancillary range see page 14



FLEXIGRID

Tough at work - gentle on the environment

Combining a higher profile with an open grid and an aggressive grip surface Flexigrid delivers slip resistance and drainage where spillage, debris and metal shards are an issue!

Available in both roll and modular tiles, Flexigrid is versatile enough to cover both regular and irregular floor areas.

Flexigrid is both 100% recyclable and in turn made from up to 100% recycled material - with a minimum guaranteed content of 30%.

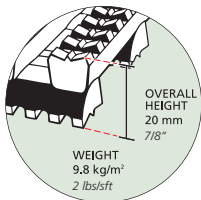

| PRODUCT | HEIGHT mm (in) | LENGTH m (ft) | WIDTH OPTIONS cm (ft) |
|-------------------|----------------|---------------|-----------------------|
| Flexigrid | 20 (7/8") | 5 (16'6") | 60 (2) 91 (3') |
| | 20 (7/8") | 10 (33') | 60 (2) 91 (3') |
| Flexigrid modules | 20 (7/8") | 1.8 (6') | 60 (2) 91 (3') |

Product Code F2G



For ancillary range see page 14

◆ Loves tough environments

◆ Chemical, oil and acid resistant

◆ Top rated drainage certification

◆ High slip resistant certification DIN 51130 R11

◆ Made from 100% recycled materials

THE MAIN BENEFITS

Standard colour
BLACK

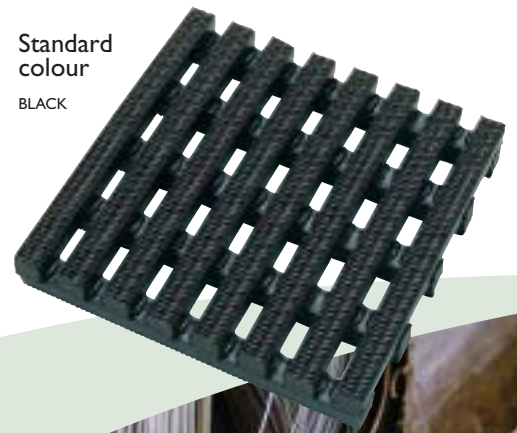

FIRMAGRIP

Close mesh matting

For where small wheeled traffic and trolleys are in use, close mesh matting, with the additional stability its construction provides, is a perfect solution.

Firmagrip is a quality close mesh matting that is dense enough to prevent smaller components falling through, yet is so effective at drainage it carries the highest certification. Add to that excellent slip resistance and you've got a real winner.

Standard colours

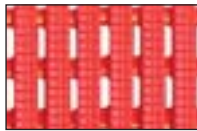

RED



GREEN



BLACK

| PRODUCT | HEIGHT mm (in) | LENGTH m (ft) | WIDTH OPTIONS cm (ft) | | |
|-----------|----------------|---------------|-----------------------|---------|----------|
| Firmagrip | 14 (9/16") | 10 (33') | 60 (2') | 91 (3') | 122 (4') |

Product Code FMG



For ancillary range see page 14



- ◆ Ideal for small wheeled traffic
- ◆ Highest fluid drainage certification
- ◆ Small components don't fall through

THE MAIN BENEFITS

- ◆ Good slip resistance
DIN 51130 R11
- ◆ Multi purpose, quick and easy to install

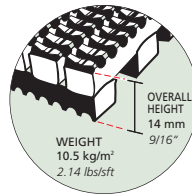

HERONGRIPA

Animal fat resistant matting

Developed by Plastex primarily for the food processing industry, Herongripa is a matting solution, which is resistant to animal fat deposits. It is made from an exceptionally hardwearing vinyl in roll format with a wide spaced open grid format to allow waste and by-products to fall through. A feature which keeps the floor free of slippery and potentially hazardous matter and assists hygiene control. It's the ideal product for safety and comfort in standing areas of food production.



◆ Animal fat resistant

◆ Efficient fluid and waste drainage

◆ Slip resistant and hygienic

◆ Roll format ensures minimum of seams

THE MAIN BENEFITS

| PRODUCT | HEIGHT mm (in) | LENGTH m (ft) | WIDTH OPTIONS cm (ft) | | |
|------------|----------------|---------------|-----------------------|---------|----------|
| Herongripa | 15 (5/8") | 5 (16'6") | 60 (2') | 91 (3') | 122 (4') |
| Herongripa | 15 (5/8") | 10 (33') | 60 (3') | 91 (3') | 122 (4') |

Product Code HGA

Standard colour



TERRACOTTA



For ancillary range see page 14

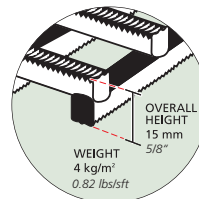

GRIP ROCK

Versatile commercial catering matting that rocks!

Grip rock is tested to DIN 51130 and assessed at R13, the highest slip resistance rating (>40 degree incline).

The unique combination of textured ceramic beads and crushed garnets gives a surface of incredible slip resistance - even in conditions where water, oil and grease may be spilled. Not only that, it's durable, thin, easy to clean and move. In fact it's perfect for all commercial catering needs. Despite being only 3mm (1/8") thick it has three layers, the tough grippy rock surface is backed by a fibreglass middle layer for strength and polyurethane backing to provide grip to most floor surfaces.

This is an important development in kitchen safety where slips and trips cause 75% of all reported serious injuries.

◆ Unique 'rock' surface

◆ High slip-resistance even in water, grease and oil - DIN51130 R13

◆ Extremely tough and durable

◆ Simple to install

◆ Easy to handle, clean and maintain

THE MAIN BENEFITS

| PRODUCT | HEIGHT mm (in) | SIZE cm (ft) |
|------------------|----------------|-------------------------|
| Grip Rock module | 3 (1/8") | 91 x 152 (3' x 5") |
| Grip Rock roll | 3 (1/8") | 12m x 91cm (39'4" x 3') |

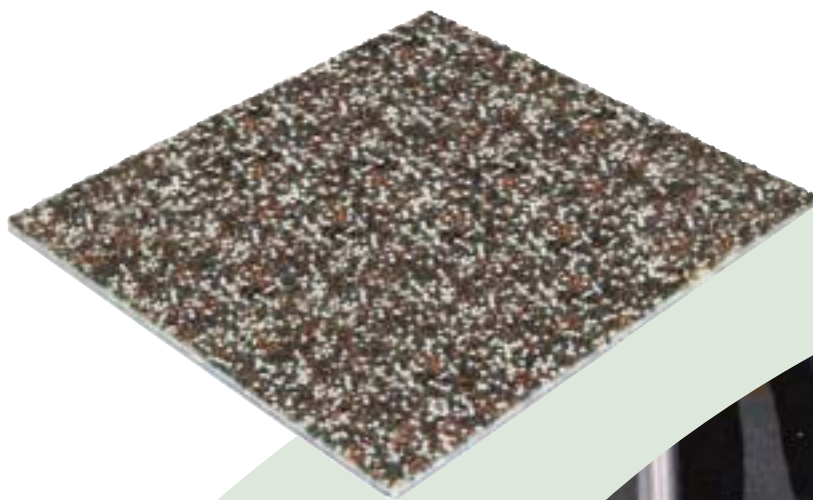
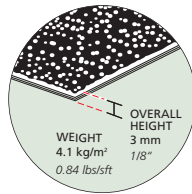

Product Code GPR

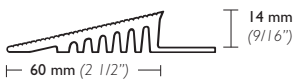
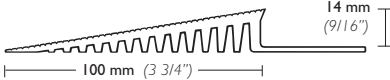
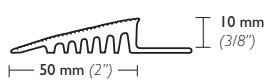

Workplace matting ancillaries

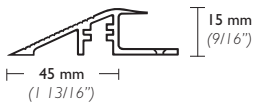
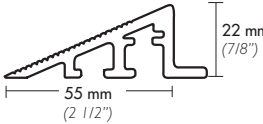
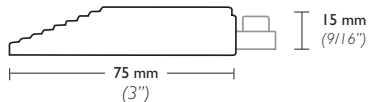
| PRODUCT | EDGING STRIPS | | |
|---|--|---|--|
| Flexible PVC ramped edging for surface mounted applications | Flexible PVC edging roll  | Flexible PVC edging roll  | Flexible PVC edging roll  |
| VYNAGRIP | ● | ● | |
| HERONAIR | | | ● |
| HERONGRIPA | ● | ● | |
| FIRMAGRIP | ● | ● | |
| | 60mm (2 1/2") x 10.1m (33') length with welding paste Colours: Dark Grey <i>EDGE/6-G</i> Black <i>EDGE/6-B</i> Dark Brown <i>EDGE/6-BRN</i> Oxford Blue <i>EDGE/6-OBL</i> Holly Green <i>EDGE/6-GNH</i> Yellow <i>EDGE/6-Y</i> | 100mm (3 3/4") x 10.1m (33') length with welding paste Colours: Dark Grey <i>EDGE/C</i> Yellow <i>EDGE/Y</i> Black <i>EDGE/BLK</i> | 50mm (2") x 10.1m (33') length with welding paste Colours: Dark Grey <i>EDGE/LPG</i> Black <i>EDGE/LPB</i> 2 rolls per pack |

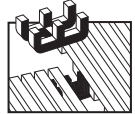
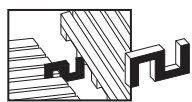
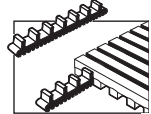
| PRODUCT | EDGING STRIPS | | |
|--|--|--|---|
| Aluminium ramped edging for surface mounted applications | Aluminium section  | Aluminium section  | Flexible PVC edging strip (available in male or female)  |
| VYNAGRIP | ● | | |
| FLEXIGRID | | ● | |
| HERONGRIPA | ● | | |
| FIRMAGRIP | ● | | |
| RUBBAGRID | | | ● |
| | 45mm (1 13/16") x 2m (6'6") length with fixing screws and plugs Colours: Anodised Aluminium <i>EDGE/ALU</i> Powder Coated Yellow <i>EDGE/YEC</i> | 55mm (2 1/2") x 2m (6'6") length with fixing screws and plugs Colour: Anodised Aluminium <i>EDGE/20MM</i> | 75mm (3") x 1m (3'3") length with fixing screws and plugs Colours: Black, Yellow, Terracotta Male <i>EDGE/RGM</i> Specify colour Female <i>EDGE/RGF</i> Specify colour |

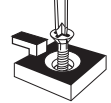
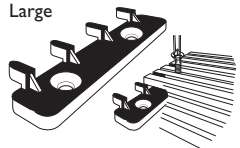
| PRODUCT | CONNECTOR CLIPS | | | | FLOOR HOOKS | |
|---|---|--|---|---|--|--|
| Floor Hooks For securing sections of matting to floor Connector Clips For joining sections of matting together |  Dual Purpose |  Side to end |  Side to side |  Snap Track 2 part strip | Small  | Large  |
| VYNAGRIP | ● | ● | | ● REGULAR | ● | ● |
| HERONAIR | ● | | | ● LOW PROFILE | | |
| HERONGRIPA | | | | | ● | |
| FIRMAGRIP | | | ● | ● REGULAR | | |
| | Supplied in packs of 10 <i>CCDP</i> | Supplied in packs of 10 <i>VYNICCSE</i> | Supplied in packs of 10 <i>FCC</i> | Welding paste included Colour: Dark Grey Standard lengths 2.5m (8'2") <i>ST/RH</i> Low Profile 1.8m (5'11") <i>ST/LP</i> | Supplied in packs of 10 with screws & plugs <i>VYNI/FHK</i> | Supplied in packs of 10 with screws and plugs <i>FHK/L</i> |

Ancillary part ordering codes shown in italics. Power shears and secateurs are also available for cutting matting to size and shape. See price list separate for details.

We make our matting, and that makes all the difference

When you buy Plastex matting you're also buying our extensive know-how that comes from over 45 years of designing, testing and manufacturing matting solutions for a diverse range of applications; knowledge we apply to make sure we find exactly the right solution for you.

This is important as an incorrectly specified product may actually increase risk. For example using a mat designed for bare feet in a workplace area could potentially increase slip accidents. That's why simply picking a product from a web page may not deliver the correct solution.

Talk to Us

To make sure you get the right mat for the right reasons, talk to us and our distributors.



Plastex

Three levels of service

Once we've established your exact need, we'll recommend the product that is right for you, from our three levels of service.

General Purpose

We have an extensive range of general purpose matting designed for various environments. So whether you're looking for comfort, slip resistance, soil removal or increased hygiene we'll have the product for you.

Specialist

We have also built up a full range of products for demanding specialist environments such as light and heavy industrial, food preparation big and small.

Bespoke

If we can't exactly meet your needs from our current range we'll design and manufacture a mat specifically for you.

Whatever your requirement we'll put all our knowledge and care into delivering exactly the mat you need, on time and on budget - *'a mat for all reasons'*.

Testing and Measurement

In our constant pursuit of excellence, we subject our products to the rigors of scientific testing. This includes external testing through international bodies, but we don't stop there. If an external test doesn't exist, we will commission a university research project. Plastex continually strive to ensure we maintain the highest standards expected by our customers worldwide.

www.plastexmatting.com



The 45+ products within the Plastex range of matting and flooring offer **"a mat for all reasons"**.

To make it easier for you to choose the right mat for the right reason, we've divided our range into the sections below. Simply pick the section that best suits your need, and then use the segmentation chart you'll find at the front of each section to help you make your final choice.

Section brochures available :-



| Workplace | |
|------------------------|----|
| SLIP RESISTANT MATTING | |
| Product Index | |
| Firmagrip | 11 |
| Flexigrid | 10 |
| Floorline | 8 |
| Grip Rock | 13 |
| Heronair | 6 |
| Herongripa | 12 |
| Rubbagrip Open | 9 |
| Vynagrip | 4 |

Full manufacturer warranty - another good reason to choose Plastex

If you follow our simple fitting and maintenance instructions, all Plastex flooring and matting will give excellent and long service. But for extra peace of mind, and in the unlikely event of a Plastex product being faulty, we offer a full refund or replace warranty. The warranty periods vary depending on the product, you can find full terms and details at

www.plastexmatting.com/matfax/doc.php?doc_id=167&action=inline

Ensure you have been supplied with a genuine Plastex product.

By choosing Plastex you're benefiting from our extensive know how that comes from over 45 years of designing, testing and making matting for an extensive range of customers and reasons.

Since July 2010, we have been embossing the trade marked names on the underside of our grid matting.

The programme began with Vynagrip and is being extended to include all dual layer grid rolls manufactured in the UK and USA. In addition to the roll out period, there will be a time lag in the supply chain, so if you have any doubt that you've been supplied a genuine Plastex mat, where you cannot see the trademark on the underside, ask your distributor to get us to confirm it.

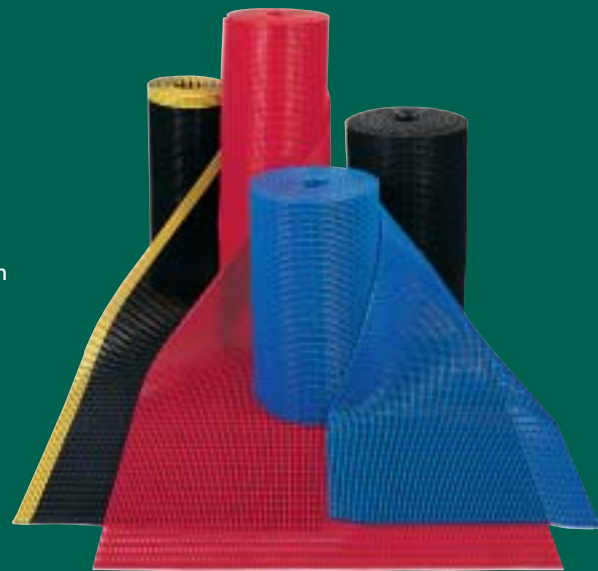

Plastic Extruders Ltd.

Russell Gardens, Wickford,
Essex SS11 8DN, England
Tel: 01268 571116 Fax: 01268 560027

www.plastex.co.uk

Plastex Matting Inc.

120 55th Street NE,
Fort Payne, AL 35967 USA
Tel: 256 845 7725 Fax: 256 845 6786

www.plastexmatting.com



THE SYMBOL OF EXCELLENCE